



SMART GARBAGE MANAGEMENT USING GSM TECHNOLOGY

Deepali A. Ghanwat*, Sumeet N. Pitroda, Kiran J. Takate** & Ketan S. Darkunde****

* Assistant Professor, Shri Chhatrapati Shivaji Maharaj COE, Nepti, Ahmadnagar, Maharashtra

** BE Scholar, Shri Chhatrapati Shivaji Maharaj COE, Nepti, Ahmadnagar, Maharashtra

Abstract:

With increase in population, the scenario of cleanliness with respect to garbage management is degrading tremendously. The overflow of garbage in public areas creates the unhygienic condition in the nearby surrounding. It may provoke several serious diseases amongst the nearby people. It also degrades the valuation of the area. To avoid this and to enhance the cleaning, a proposed in this paper. In the proposed system, the level of garbage in the dustbins is detected with the help of Sensor systems, and communicated to the authorized control room through GSM system. Microcontroller is used to interface the sensor system with GSM system. A GUI is also developed to monitor the desired information related to the garbage for different selected locations. This will help to manage the garbage collection efficiently.

Index Terms: IR Sensor, Microcontroller, GSM & GUI

1. Introduction:

Due to rapid population growth, disorganization of city governments, a lack of public awareness and limited funding for programs waste management is become a global problem. The Central Public Health and Environmental Engineering Organization (CPHEEO) has estimated that waste generation in India is as much as 1.3 pounds per person per day. This figure is relatively low, compared to the 4.6 pounds of waste generated per person per day in the United State (U.S.). But the U.S. population was close to 307 million in July 2009, whereas India's population was 1.2 billion. These statistics mean that India could be generating as much as 27 million more tons of waste than the U.S. per year [1]. Governments of India have struggled for years to find a way to manage the country's ever increasing amount of trash. According to the survey carried out in 1994 the garbage produced in Mumbai is 5800 tons per day. Municipal Corporation of Greater Mumbai (MCGM) operates a huge fleet of 983 Municipal and Private Vehicles for collection of waste making 1396 number of trips each day. Solid Waste Management (SWM) expenditure outlay in the year 2007-08 is Rs.10479.3 Million. But still there is overflow of garbage in many areas in Mumbai. To avoid this smart garbage management system is developed in this paper [2].

System description is discussed in section II. Section III includes the block diagram of the project work, Section IV includes implementation of the project and section V include graphical user interface.

2. System Description:

For the garbage detection, weight sensor can be used. It gives the weight of the garbage in the dustbin. But it doesn't provide any information about the level of the garbage in the dustbin [3]. Hence author used Infrared (IR) sensor for garbage detection. IR sensor radiates light which is invisible to the human eye because it is at infrared wavelengths, but it can be detected by electronic devices. IR sensor section consists of the IR transmitter and IR receiver. IR transmitter consists of LED which send the IR beam. To receive this beam IR receiver, TSOP1738 is used. The output of TSOP1738 directly connected to the microcontroller and it has high immunity against

ambient light and other electrical disturbances. It is able to transfer data up to 2400 bits per second. It has three pins. It needs the power supply of 5V. The output of receiver is Pulse Code Modulation (PCM) remote control, which is taken from third pin and it is active LOW. The output of receiver will be low when 38 KHz infrared light fall on it. IC 555 is used to design the IR transmitter of 38 KHz.

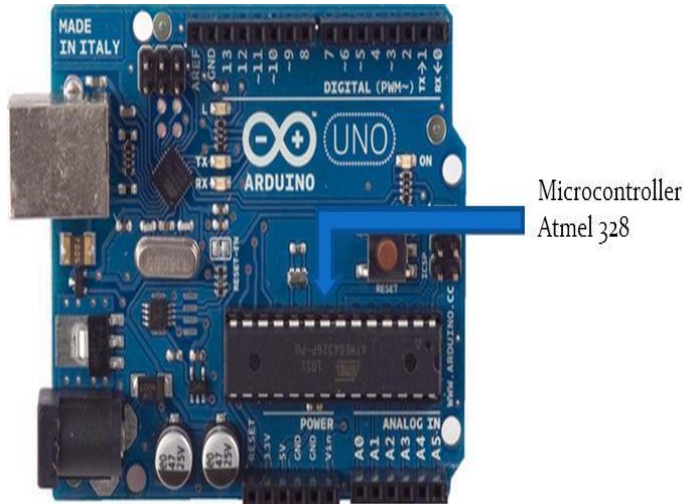

Figure 1: Arduino uno Board

Microcontroller is a small computer on a single integrated circuit containing a processor core, memory, and programmable input/output peripherals. It is used in automatically controlled products and devices, such as automobile engine control systems, remote controls appliances, power tools and other embedded systems. Microcontroller Atmel328 is used in this work. Figure 1 shows the Arduino uno board used for programming which includes Microcontroller Atmel328. This Microcontroller is a high-performance 8-bit AVR RISC-based microcontroller combines 32KB ISP flash memory with read-while-write capabilities, 1KB EEPROM, 2KB SRAM, 23 general purpose I/O lines, 32 general purpose working registers, three flexible timer/counters with compare modes, SPI serial port, 6-channel 10-bit A/D converter

For communication purpose ZigBee technology can also be used in the transmitter section [4]. ZigBee is a wireless networking standard that is aimed at remote control and sensor applications which is suitable for operation in harsh radio environments and in isolated locations. But, the main disadvantage of ZigBee is short range, low complexity, and low data speed. Therefore GSM is more advantages over ZigBee for communication. Hence author use GS modem. A GSM modem is a specialized type wireless modem that works with a GSM wireless network. It accepts a SIM card, and operates over a subscription to a mobile operator, just like a mobile phone. A GSM modem can be an external device or a PC Card / PCMCIA Card. An external GSM modem is connected to a computer through a serial cable or a USB cable. When a GSM modem is connected to a computer, this allows the computer to communicate over the mobile network. While these GSM modems are most frequently used to provide mobile internet connectivity, many of them can also be used for sending and receiving SMS and MMS message. GSM Modem sends and receives data through radio waves. In this project GSM 900 modem is used to send the messages which are shown in figure 2. It consists of a GSM/GPRS modem with standard communication interfaces like RS-232 (Serial Port), USB, so that it can be easily connected to the other devices. The power supply circuit is also built in the module that can be turn ON by using a suitable adaptor.

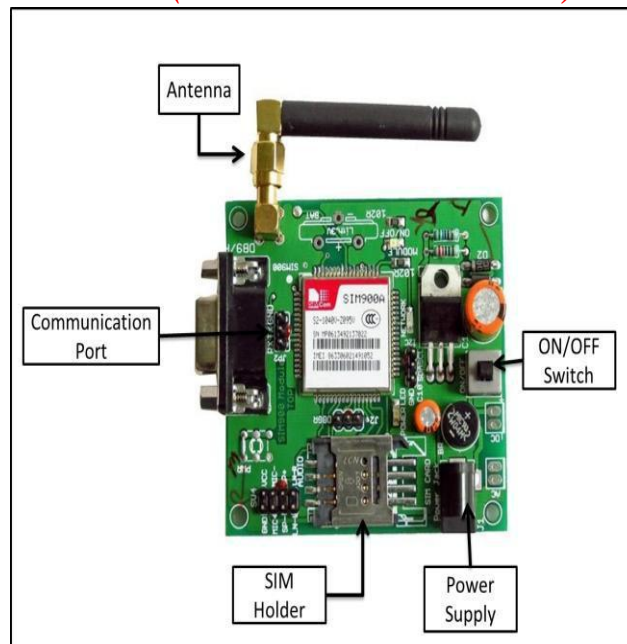

Figure 2: GSM Modem

3. Block Diagram:

A. Transmitter Sections:

The Figure 3 shows the block diagram of transmitter section. Level detector consists of IR sensors which are used to detect the level of the garbage in the dustbin. The output of level detector is given to microcontroller. Four IR sensors are used to indicate the different levels of the amount of the garbage collected in the dustbin which is placed in public area. When the dustbin is filled up to the highest level, the output of fourth IR receiver becomes active low. This output is given to microcontroller to send the message to the Control room via GSM module as shown in figure 6.

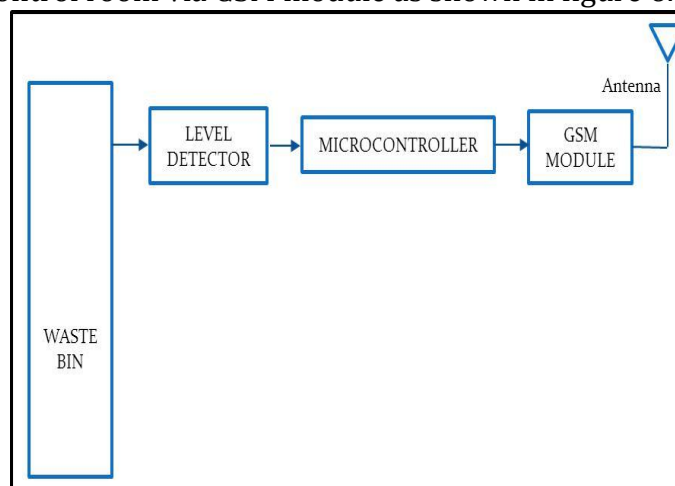

Figure 3: Transmitter Section

B. Receivers Section:

The figure 4 shows the block diagram of receiver section. At receiver, control room is present where all the activities are manage. The number of the control room is depends on dustbins present in the area. The person sitting in the control room monitors the entire system. A GSM Module is connected to the computer of the control room through microcontroller [5]. The entire system is monitor by the person sitting in the control room. The same GSM Module is used to send the message to the contractor for cleaning the dustbin. GUI is developed using MATLAB software. This GUI will be

displayed on the computer screen in the control room to display the status of the garbage level in the dust bin as shown in figure 6.

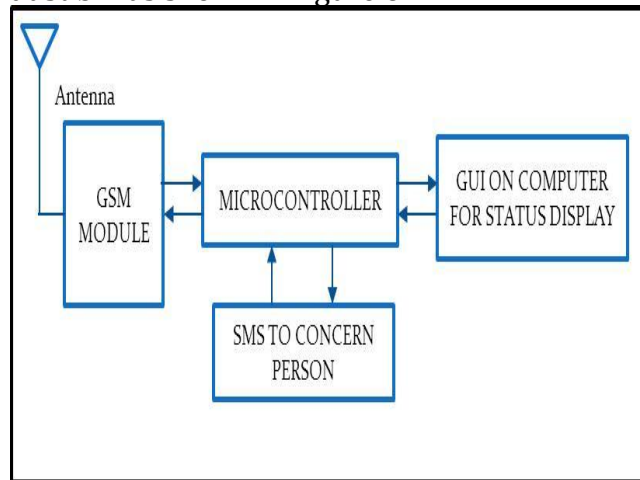

Figure 4: Receiver Section

4. Implementation of Project:

The figure 5 shows the circuit diagram of IR transmitter using the IC 555. Since the PCM carrier frequency of TSOP1738 is 38 KHz, so to transmit the accurate beam, IC 555 is used in Astable Multivibrator mode. This is achieved by using two resistors (R1 and R2) and the capacitor (C). The value of resistors and capacitors are calculated using the following equations.

$$T_{high} = 0.693(R1+R2)C \quad (1)$$

$$T_{low} = 0.693R_2 C \quad (2)$$

$$T = T_{high} + T_{low} \quad (3)$$

$$F = 1/T \quad (4)$$

Where T_{high} and T_{low} are the time period for which the output of IC 555 is HIGH and LOW respectively; T is total time period of the output of IC 555 and „F“ is the output frequency. Output of the circuit shown in figure 5 is IR beam and it is taken from IR LED. Furthermore this beam is used to detect the garbage level.

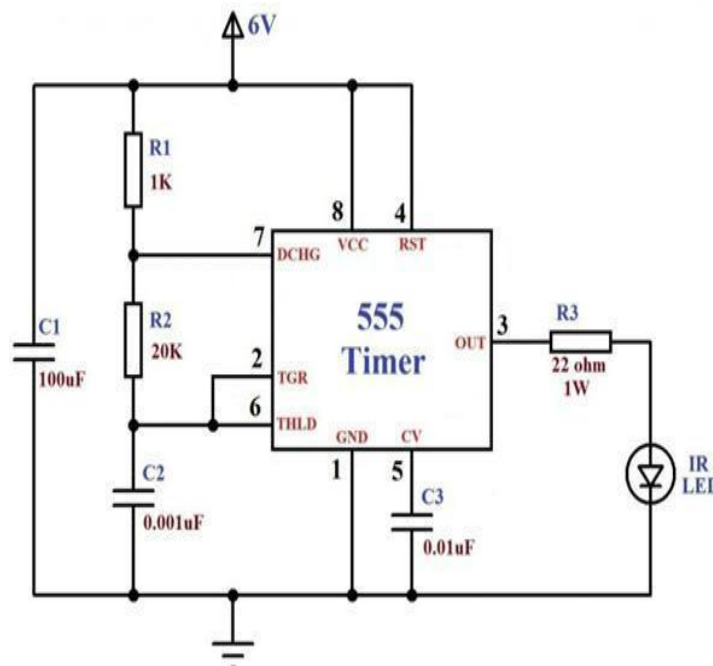

Figure 5: IR Sensor Transmitter

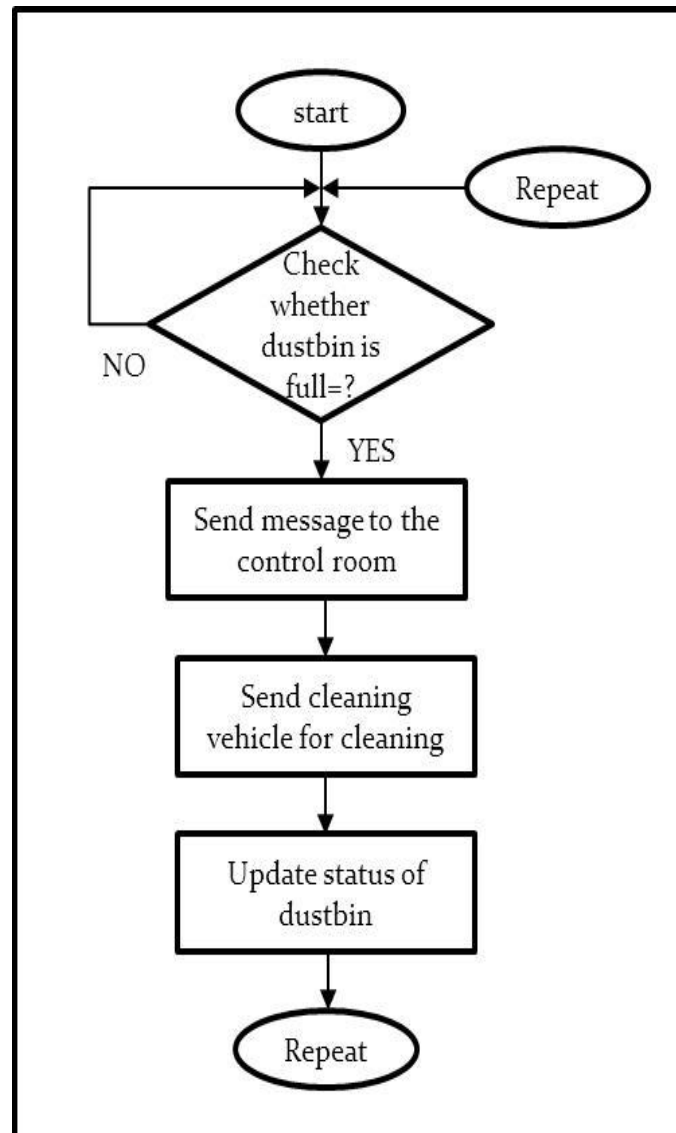

Figure 6: Flow chart of working

The IR sensor arrangement is act as level detector .The output of level detector is given to the microcontroller (as shown in figure 3). The AT commands are used to facilitate the messaging service through the GSM Module. This program is burned in the microcontroller with the help of Arduino software (IDE) version1.6.1. These messages consist of information of garbage levels of respective dustbins. Depending on the information sent to control room, the authority informs the concern person of the respective area about garbage level. Then the concerned person makes sure that the garbage of that particular area is collected by sending the cleaning vehicles.

5. Graphical User Interface:

GUI is a graphical user interface which provides a user friendly environment to carry certain operations. The GUI for smart garbage management system proposed by authors is developed using MATLAB 2010 software and discussed in this section. In this paper, GUI is used to display different parameters and information regarding the garbage and garbage collection viz. location of dustbin, status of the dustbin, date & time of garbage collection as shown in Figure 7 The GUI has also the provision to display the name and mobile number of the contractor, who is responsible for cleaning the dust bin of particular location.



Figure 7: GUI interface on MATLAB

6. Conclusion:

This paper shows the implementation of smart garbage management system using IR sensor, microcontroller and GSM module. This system assures the cleaning of dustbins soon when the garbage level reaches its maximum. If the dustbin is not cleaned in specific time, then the record is sent to the higher authority who can take appropriate action against the concerned contractor. This system also helps to monitor the fake reports and hence can reduce the corruption in the overall management system. These reduce the total number of trips of garbage collection vehicle and hence reduce the overall expenditure associated with the garbage collection. It ultimate helps to keep cleanness in the society. Therefore, the smart garbage management system makes the garbage collection more efficient. The use of solar panels in such systems may reduce the energy consumption. Such systems are vulnerable to plundering of components in the system in different ways which needs to be worked on.

7. References:

1. Marian Look, "Trash Plant: India", earth911B.
2. Basic Feature, "Solid waste Management Project by MCGM".
3. Microtronics Technologies, "GSM based garbage and waste collection bins overflow indicator", September 2013.
4. Hindustan Embedded System, "City Garbage collection indicator using RF (ZigBee) and GSM technology".
5. Z embedded, "GSM modem interfacing with 8051 for SMS" August 2012.