



RANDOMIZED CLUSTER HEAD SELECTION STRATEGY FOR DENSE WIRELESS SENSOR NETWORKS

Dr. E. Gajendran*, Dr. J. Vignesh & Dr. S. R. Boselin Prabhu*****

* Associate Professor, Department of Computer Science and Engineering, Sree Dattha Group of Institutions, Hyderabad, Telangana

** Professor, Department of Computer Science and Engineering, Sreyas Institute of Engineering and Technology, Hyderabad, Telangana

*** Associate Professor, Department Electronics and Communication Engineering, VSB Engineering College, Karur, Tamilnadu

Cite This Article: Dr. E. Gajendran, Dr. J. Vignesh & Dr. S. R. Boselin Prabhu, "Randomized Cluster Head Selection Strategy for Dense Wireless Sensor Networks", International Journal of Multidisciplinary Research and Modern Education, Volume 3, Issue 1, Page Number 414-420, 2017.

Copy Right: © IJMRME, R&D Modern Research Publication, 2017 (All Rights Reserved). This is an Open Access Article distributed under the Creative Commons Attribution License, which permits unrestricted use, distribution, and reproduction in any medium, provided the original work is properly cited.

Abstract:

A distinctive sensor node consumes a great deal of its energy during wireless communication. This research work suggests the development of a well evaluated distributed clustering scheme for dense wireless sensor network fields, which gives improved performance over the existing clustering algorithm LEACH. The two thrashing concepts behind the proposed scheme are the hierarchical distributed clustering mechanism and the concept of threshold. Energy utilization is appreciably reduced, thereby greatly prolonging the lifetime of the sensor nodes.

Index Terms: Wireless Sensor Network, Sensor Node, Cluster Head, Base Station, Residual Energy, Energy Utilization & Network Lifetime

1. Introduction:

These wireless sensor nodes assemble data from a sensing area which is probably inaccessible for humans. Data gathered from the sensing field are usually reported to remotely located base station (BS). This high redundancy of sensing power can greatly improve the sensing resolution and make sensor networks robust to swiftly varying environment. Some promising applications of wireless sensor networks are wildlife habit study, environmental observation and health care monitoring [1]-[2]. Since wireless sensor nodes are power-constrained devices, long-haul transmissions ought to be kept minimum in order to expand the network lifetime [3-6]. Hence, direct communications between nodes and the base station are not intensely encouraged. An effectual methodology to perk up efficiency is to position the network into several clusters (figure 1), with every cluster electing one node as its leader or cluster head (CH). A cluster head collects data from other sensor nodes in its cluster, directly or hopping through added nearby nodes. The data composed from nodes of the same cluster are extremely correlated. Data can be amalgamated during the data aggregation course. The fused data will then be transmitted to the base station straightly or by multi-hop fashion. In such an arrangement, only CHs are required to transmit data over larger distances.

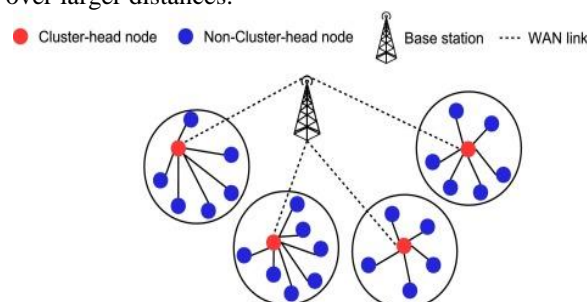

Figure 1: Clustering method in a sensor network

This paper gives a deep description about energy efficient hierarchical distributed clustering algorithm. The left over nodes will need to do only short-distance transmission. To distribute the workload of the cluster heads amidst the wireless sensor nodes, cluster CHs will be reelected from time to time. Clustering follows some likely advantages like localizing route setup within a cluster radius, utilization of bandwidth proficiently and makes best use of network lifetime. Since clustering makes use of the mechanism of data aggregation, needless communication between the sensor nodes, CH and BS is avoided [7-12]. Energy consumption of wireless sensor nodes is greatly trimmed down and the overall network life span can thus be prolonged [13-18]. The rest of the paper is prepared as follows. A literature review of distributed clustering algorithms is given in Section II. The

hierarchical distributed clustering algorithm giving motivation to this work is described in Section III. Section IV elaborates the particulars of the simulation results. Finally the last part gives the conclusion.

2. Certain Investigations:

Broad research efforts have been made to minimize the energy consumption and to prolong the lifetime of WSNs. The algorithms described in this section are totally distributed and CH changes from node to node based on some parameters. They tend to differ mainly in the methodology by which the CH is elected. Bandyopadhyay and Coyle anticipated EEHC, which is a randomized clustering algorithm which organizes the sensor nodes into hierarchy of clusters with an aim of minimizing the total energy spent in the system to communicate the information collected by the sensors to the information processing center. It has uneven cluster count, the immobile CH aggregates and relays the data to the BS. It is valid for extensive large scale networks. The odd drawback of this algorithm is that, few nodes reside un-clustered throughout the complete clustering process. Barker, Ephremides and Flynn proposed LCA [19], which is chiefly developed to avoid the communication collisions among the nodes by using a TDMA time-slot. It makes use of single-hop scheme, attains enhanced degree of connectivity when CH is selected randomly. The updated version of LCA, the LCA2 was implemented to diminish the number of nodes compared to the original LCA algorithm. The main fault of this algorithm is, the single-hop clustering results in the formation of many clusters and much energy is washed out. Nagpal and Coore anticipated CLUBS [20], which is implemented with a thought to form overlapping clusters with maximum cluster diameter of two hops.

The clusters are formed by local broadcasting and its convergence depends on the local compactness of the wireless sensor nodes. This algorithm can be implemented in asynchronous environment without dropping efficiency. The major problem is the overlapping of clusters, clusters having their CHs within one hop range of each other, both clusters will crumple and CH election process will restart. Demirbas, Arora and Mittal brought out FLOC [21], which exhibits double-band scenery of wireless radio-model for communication. The nodes can commune reliably with the nodes in the inner-band range and unreliably with the nodes that are in the outer-band range. It is scalable and thus exhibits self-healing potential. It achieves re-clustering in even time and in a local manner, thereby finds valid in large scale networks. The key problem of the algorithm is, the nodes in the outer band exercise unreliable communication and the messages have the highest probability of getting vanished during communication. Ye, Li, Chen and Wu proposed EECS [22], which is based on the guessing that all CHs can communicate straight with the BS. The clusters have variable size, such that those nearer to the CH are larger in size and those farther from CH are smaller in size.

It is really energy efficient in intra-cluster communication and excellent upgrading of network lifetime. EEUC [23] is proposed for unvarying energy consumption within the network. It forms unlike clusters, with an assumption that each cluster can have variable sizes. Probabilistic selection of CH is the crucial drawback of this algorithm. Few nodes may be gone without being part of any cluster, thereby no assurance that every node takes part in clustering mechanism. Yu, Li and Levy proposed DECA, which picks CH based on residual energy, connectivity and node identifier. It is deeply energy efficient, as it uses fewer messages for CH selection. The key trouble with this algorithm is that high possibility of incorrect CH selection which leads to discarding of all the packets sent by the sensor node. Ding, Holliday and Celik proposed DWEHC, which elects CH based on weight, a mixture of residual energy and its distance to neighboring nodes. It generates well balanced clusters, autonomous to network topology. A node possessing principal weight in a cluster is nominated as CH. The algorithm constructs multilevel clusters and nodes in each cluster reach CH by relaying through other intermediate nodes. It shows a vast improvement in intra-cluster and inter-cluster energy consumption. The foremost problem occurs due to much energy utilization by numerous iterations until the nodes settle in most energy efficient topology. HEED [2] is a well distributed clustering algorithm in which CH selection is made by taking into account the residual energy of the nodes and the intra-cluster communication cost leading to prolonged network lifetime. It is clear that it can contain variable cluster count and supports heterogeneous sensor nodes. The CH is motionless which carries out data aggregation and relaying of the fused data to the BS.

The problems with HEED are its application restricted only to static networks, the assumption of complex probabilistic methods and multiple clustering messages per node for CH selection even though it prevents arbitrary selection of CH. LEACH [1] is one of the most well-liked clustering mechanisms for WSNs and it is considered as an envoy energy efficient protocol. In this protocol, sensor nodes are grouped jointly to form a cluster. In all the clusters, one sensor node is elected arbitrarily to act as a cluster head (CH), which collects data from its member nodes, aggregates them and then forwards to the base station. It separates the action unit into several rounds and each round consists of two phases, namely set-up phase and the steady state phase. During the set-up phase, clusters are shaped and cluster heads are selected. All the sensor node creates a random number between 0 and 1. If the number is smaller than the threshold limit, the node elects itself as a cluster head for the present round. The threshold is set as follows (equation 1)

$$T(n) = \begin{cases} \frac{p}{1 - p^{*(r \bmod 1/p)}} & \text{if } n \in G \\ 0 & \text{otherwise} \end{cases} \quad (1)$$

Where p is the preferred percentage of cluster heads, r is the current round number and G is the set of sensor nodes which have not been selected as cluster head in previous $1/p$ rounds.

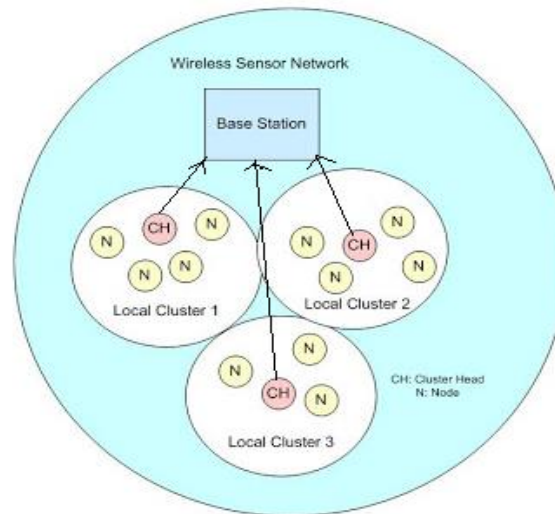

Figure 2: Assessment of LEACH algorithm

When selecting itself as a CH, the node usually broadcasts an advertisement message which contains its own ID. The non-cluster head nodes can craft a decision, which cluster to join according to the strength of the received advertisement signal. After the decision is made, every non-cluster head node should transmit a join-request message to the chosen cluster head to state that it will be a member of the cluster. The cluster head produces and broadcasts the time division multiple-access (TDMA) schedule to change the data with non-cluster sensor nodes with no collision after it receives all the join-request messages. The steady phase begins after the clusters are formed and the TDMA schedules are broadcasted. All the sensor nodes hurl their data to the cluster head once per round during their allocated transmission slot based on the TDMA schedule and in other time, they turn off the radio in order to diminish the energy consumption. However, the cluster heads must stay awake all the time. Therefore, it can get every data from the nodes within their own clusters. On receiving all the data from the cluster, the cluster head carry out data aggregation and onwards it to the base station directly. This is the whole process of steady phase. After a definite predefined time duration, the network will walk into the next round. LEACH is the simplest clustering protocol which prolongs the network lifetime when compared with multi-hop routing and static routing. However, there are still some beating drawbacks that should be considered. LEACH does not take into account the residual energy to select cluster heads and to construct clusters. As a result, nodes with smaller energy may be selected as cluster heads and then die much earlier. Moreover, since a node selects itself as a cluster head only according to the assessment of probability, it is tough to guarantee the number of cluster heads and their distribution. To defeat the inadequacy in LEACH, a hierarchical distributed clustering means is proposed, where clusters are prearranged in to hierarchical layers. Instead of cluster heads directly sending the aggregated data to the base station, sends them to their next layer CHs. These cluster heads propel their data along with those received from lower level cluster heads to the next layer cluster heads. The cumulative process gets repeated and lastly the data from all the layers reach the base station.

3. Proposed System:

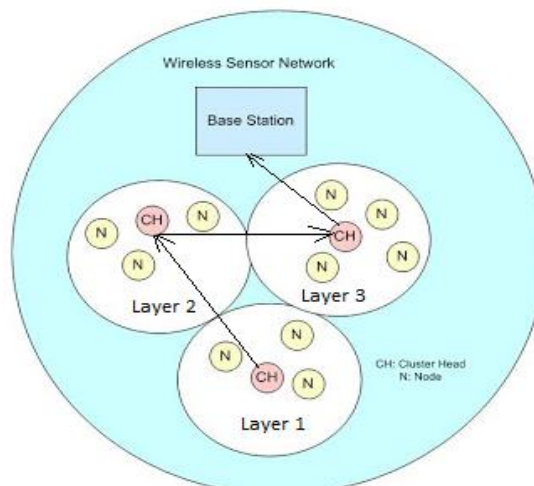

Figure 3: Assessment of the proposed algorithm

The first step in the creation of LEACH (Low Energy Adaptive clustering of Hierarchy), is the formation of clusters. More specifically, each sensor nodes decides whether or not to turn into the cluster head for the present round. The choice is based on the priority and on the number to time the node has been a cluster head so far. The cluster nodes bring jointly the data and send them to the cluster head. The radio to each cluster nodes can be turned off when there is no sensing takes place. When all the data have been received, the cluster head aggregates the data in to distinct composite signal. The composite signal is then sent to the BS directly. LEACH protocol has the flaw, when periodic transmissions are unnecessary, thus causing pointless power consumption. The election of cluster head is based on priority, hence there is a option for weaker nodes to be drained because they are elected to be cluster heads as often as the stronger nodes. Moreover, the protocol is based on the assumptions that all nodes begin with the same amount of energy capacity in each election round and all the nodes can transmit with enough power to reach the base station if needed. Nevertheless, in many cases these assumptions are merely impractical. Also the base station should keep track on the sensor nodes in order to decide which node has the highest residual energy. Hence needless transmissions happen between the base station and cluster nodes, thereby causing increased power consumption.

The projected work suggests a new idea over the existing techniques. In case of existing technique (figure 2), the aggregated data is sent to the base election directly by the CH, which leads to additional energy usage. In the proposed algorithm the aggregated data is forwarded only to the next layer cluster head (figure 3), cutting down the communication distance between CH and the BS. Two thresholds are engaged namely hard threshold and soft threshold. Hard threshold is the bare minimum possible value, of an attribute to activate a wireless sensor node to switch on its transmitter and transmit to the cluster head. Soft threshold is a modest change in the value of the sensed attribute that triggers the node to switch on its transmitter and transmit data. The hard threshold tries to trim down the number of transmission by allowing their nodes to transmit only when the sensed aspect is beyond a critical value. In a similar way, the soft threshold further lessens the number of transmissions that might have or else occurred when there is little or no change in the sensed attribute. At each cluster change, the values of both the thresholds can be altered and thus enabling the user to control the tradeoff between energy efficiency and data accuracy. This technique reduces unwanted transmissions, trimming down the energy utilization. The main actions in the set-up phase are election of candidate nodes, selection of cluster heads, scheduling at every cluster and discovery of cluster head for CH-to-CH data transmission. During set-up phase, each node first decides whether or not it can become a candidate node in each region for the current round. This selection is based on the value of the threshold $T(n)$ as used in LEACH protocol. As seen in equation 1, p must be given a large value in order to elect many candidate nodes.

The cluster heads are elected amid the candidate nodes. An advertisement message is used to elect cluster heads. For this, the candidate nodes employ a CSMA MAC protocol. Every candidate node broadcasts an advertisement message within its transmission range and is dependent on the utmost distance between these levels. In the proposed scheme, the advertisement range is given twice the maximum distance to cover other levels. When a candidate node is situated within $a \times \text{Advertisement Range}$ where the value of a is predetermined between 0 and 1, it has to give up the ability of candidate node and has to end up joining the competition. An ordinary node, by contrast, decides the cluster to which it will fit in for this round. This preference is based on the signal strength of the advertisement message. After each node has decided to which cluster it belongs, node have to transmit its data to the suitable cluster head. After cluster head receives all the messages from the nodes that would like to be incorporated in the cluster and based on the number of nodes contained in the cluster, the cluster head creates a TDMA schedule and allots each node a time slot when it can transmit. Each cluster head broadcasts this equivalent schedule back to the nodes in the cluster. After schedule creation, each cluster head performs cluster head detection to discover an upward cluster head to reach the sink. For this, each cluster head employs two-way handshake technique, with REQ and ACK messages. Every cluster head broadcasts REQ message within the advertisement range. Upward CH on receiving this REQ message transmits ACK message back to the CH that had transmitted the REQ message.

The steady-state phase of the planned scheme is analogous to other cluster-based protocols. Major activities of this phase are sensing and transmission of the sensed data. Every nodes senses and transmits the sensed data to its cluster head according to their own time schedule. When all the data has been received, the cluster head carry out data aggregation in order to reduce the amount of data. Lastly, each cluster head transmits data to the sink along the CH-to-CH routing path which have been fashioned during the set-up phase. After all the data is transmitted or a definite time is elapsed, the network leaves back into the set-up phase again and the next round begins by electing the candidate nodes.

4. Simulation Works:

All the simulations were carried using GloMoSim considering 15 wireless sensor nodes. For the simulations, a network model analogous to the one used in the conventional clustering protocols is assumed with the following properties. All sensor nodes are believed to be stationary. Every sensor node initially has the same energy level. A preset sink node is located away from the edge of network.

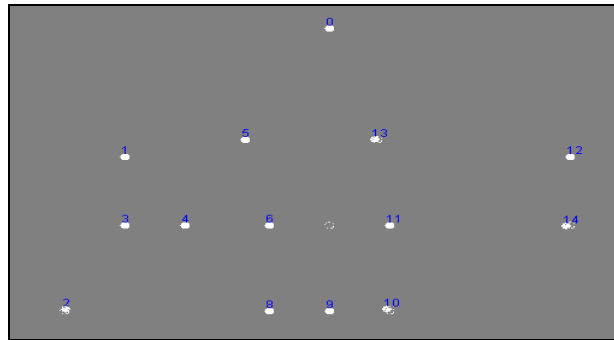

Figure 4: Nodes deployment in the projected algorithm

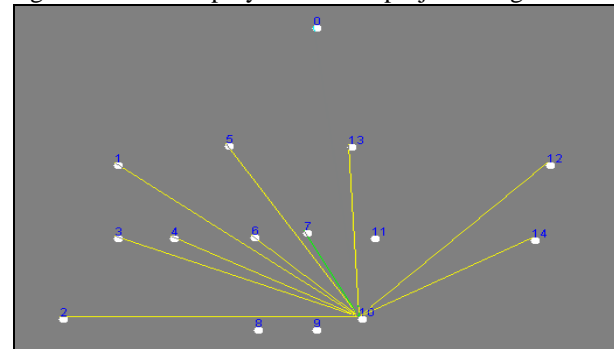

Figure 5: Cluster formation in the projected algorithm

Table 1: Simulation parameter setup

Parameter	Acronym	Values
Cluster topology (m)	C_t	100 x 100 m ²
Tx/Rx electronics constant	$E_{tx/rx}$	50nJ/bit
Amplifier constant	E_{amp}	10pJ/bit/m ²
CH energy threshold	E_{th}	10 ⁻⁴ J
Packet size	p	50 bytes
Number of nodes	N	15
Transmission range	R_{bc}	70m
Sensing range	R_{sense}	15m
Cluster range	$R_{cluster}$	30m

The sensor nodes are prepared with power control capabilities. For the experiments, the network parameters and communication energy parameters are set as shown in table 1. The exploitation of wireless sensor nodes are shown in figure 4. Here the nodes are assumed to be motionless. The nodes categorizes into hierarchical group of clusters, short while after the deployment (figure 5). The cluster heads starts forwarding the aggregated data to the subsequent higher layered CH at once after hierarchical layers are formed. The procedure gets terminated for one round when all the aggregated data reaches the base station. The radio channel is assumed to be symmetrical in behavior. Thus, the energy required to transmit a message from a source to a destination node is identical to the energy required to transmit the same message from the destination node back to the source node. Moreover, it is mainly assumed that the communication medium is barely contention free. Hence there is no need for retransmission of the data. The initial energy of every node is assumed to be the identical. The total system energy usage is the sum total of energy consumed in communication, processing, etc., which is the overall energy consumed for the entire clustering mechanism by the whole sensor network. As discussed in the preceding section, LEACH algorithm uses more energy for communication between nodes and the CHs. It distributes the loading of CHs to all the nodes in the network by toggling the cluster heads from time to time. Due to two-hop array of the network, a node far from CH will have to consume more energy than a node nearer to the cluster head. This introduces a patchy distribution of energy among the cluster members, affecting the total system energy. The irregular distribution of energy among the cluster members is avoided in the proposed algorithm by the hierarchical clustering methodology. In the proposed algorithm, fewer communication energy is necessary which could be understood from the simulations.

It uses the idea of threshold to further reduce the communication energy. From the simulation, it is also clear that the slope of LEACH algorithms is greatest, hence consuming the available energy easily compared to the proposed algorithm. Also in the proposed algorithm, parting among the layers is optimized to employ optimum power for each layer. From figure 6, the system energy usage of the proposed method is optimum for discrete number of rounds. But in case of LEACH, the energy usage is in a gradual way. This positive

performance of the proposed method is mainly by the reduction in long-haul communications between the CH and the BS.

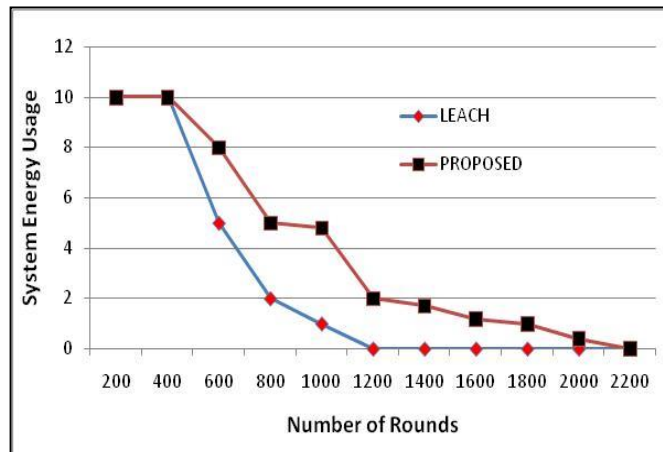

Figure 6: System energy usage versus number of rounds

The node death rate is the gauge of the number of nodes die over a particular number of rounds, from the commencement of the process. When the data rate enlarges, the node death rate also increases regularly. The networks shaped by LEACH show periodical variations in data collection time. This is due to the selection function contingent on the number of data collection process.

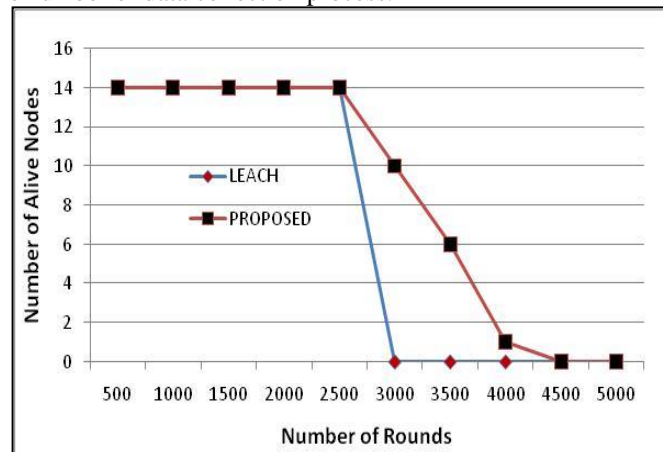

Figure 7: Node death rate versus number of rounds

As the CH selection of LEACH is a function of the number of completed data collection processes, the number of cluster varies periodically. This raises up the node death rate again. The proposed algorithm uses a limited data collection process, as the concept of hierarchical clustering is employed. Also the proposed algorithm has a brilliant control over the number of connections between the cluster nodes, cluster heads and base station. In LEACH, there is no control over the number of connections, which amplifies the data collection time, thereby increasing the data rate and node death rate. From figure 7, all the nodes expire early in 3000 rounds for LEACH algorithm. The proposed algorithm shows extended performance, as all the nodes die only in 4500 rounds. Hence, the proposed algorithm shows first-rate reduction in the node death rate compared to LEACH. This is mainly by the practice of soft threshold and hard threshold concept to reduce the redundant aggregated data transmission from cluster head to the base station.

5. Conclusion:

The main trait of this proposed algorithm compared to the existing clustering mechanism (LEACH), is that the entire aggregated data is transmitted by the cluster head to the base station by forwarding through next higher layer cluster heads. Also soft threshold and hard threshold concepts are employed to further lessen the number of transmission from cluster head to the base station. Hence energy wastage by long distance transmission is avoided, thereby reducing energy utilization to a great extent. The node death rate is reduced to a better extent compared to the existing LEACH algorithm.

6. References:

1. W. B. Heinzelman, A. P. Chandrakasan, H. Balakrishnan, (2002), "An application specific protocol architecture for wireless microsensor networks", IEEE Transactions on Wireless Communication Volume 1, Number 4, Pages 660-670.
2. Hamid Ali Abed Al-Asadi, "Temperature dependence of the lasing characteristics of vertical cavity surface emitting lasers," Engineering Journal of Technology University, Vol. 145, 1994.

3. Boselin Prabhu S.R. and Sophia S., "Environmental monitoring and greenhouse control by distributed sensor Network", *International Journal of Advanced Networking and Applications*, 5(5), 2014.
4. Boselin Prabhu S.R. and Sophia S., "Greenhouse control using wireless sensor network", *Scholars Journal of Engineering and Technology*, 2(4), 2014.
5. Hamid Ali Abed Al-Asadi, "Temperature dependence of the noise characteristics of Multi-section semiconductor lasers," *Science Journal*, vol. 7, No. 3, 2001.
6. Hamid Ali Abed Al-Asadi, "Linewidth characteristics of vertical cavity surface emitting lasers due to external optical feedback," *Science Journal*, vol. 8, 2001.
7. Boselin Prabhu S.R. and Sophia S., 'Modern cluster integration of advanced weapon system and wireless sensor based combat system', *Scholars Journal of Engineering and Technology*, 2(6A), 2014.
8. Boselin Prabhu S.R. and Sophia S., 'A review of efficient information delivery and clustering for drip irrigation management using WSN', *International Journal of Computer Science and Business Informatics*, 14(3), 2014.
9. Hamid Ali Abed Al-Asadi, "Linewidth characteristics of vertical cavity surface emitting lasers due to external optical feedback," *Science Journal*, vol. 8, 2002.
10. Hamid Ali Abed Al-Asadi, "Theoretical investigation of spectral linewidth properties of double fused 1.3 μm MQW-VCA in reflection and transition modes," *Tikrit Journal for Pure Science*, vol. 8, No. 2, 2002.
11. Boselin Prabhu S.R. and Sophia S., 'Mobility assisted dynamic routing for mobile wireless sensor networks', *International Journal of Advanced Information Technology*, 3(3), 2013.
12. Boselin Prabhu S.R. and Sophia S., 'A review of energy efficient clustering algorithm for connecting wireless sensor network fields', *International Journal of Engineering Research and Technology*, 2(4), 2013.
13. Hamid Ali Abed Al-Asadi, "Vertical cavity amplifiers and its cavity length dependence the saturation power and quantum efficiency," *Tikrit Journal of Pure Science*, vol. 9, No. 2, 2003.
14. Hamid Ali Abed Al-Asadi, "Effects of pump recycling technique on stimulated Brillouin scattering threshold: A theoretical model," *Optics. Express*, Vol. 18, No. 21, pp. 22339-22347 Impact factor: 3.88, 2010.
15. Boselin Prabhu S.R. and Sophia S., 'Variable power energy efficient clustering for wireless sensor networks', *Australian Journal of Basic and Applied Sciences*, 7(7), 2013.
16. Boselin Prabhu S.R. and Sophia S., 'Capacity based clustering model for dense wireless sensor networks', *International Journal of Computer Science and Business Informatics*, 5(1), 2013.
17. Hamid Ali Abed Al-Asadi, "Brillouin Linewidth Characterization in Single Mode Large Effective Area Fiber through the Co-Pumped Technique," *International Journal of Electronics, Computer and Communications Technologies (IJECCCT)*, Vol. 1(1), pp. 16-20, 2010.
18. Boselin Prabhu S.R. and Sophia S., 'An integrated distributed clustering algorithm for dense WSNs', *International Journal of Computer Science and Business Informatics*, 8(1), 2013.
19. Boselin Prabhu S.R. and Sophia S., 'A research on decentralized clustering algorithms for dense wireless sensor networks', *International Journal of Computer Applications*, 57(20), 2012.
20. Hamid Ali Abed Al-Asadi, "Analytical study of nonlinear phase shift through stimulated Brillouin scattering in single mode fibre with pump power recycling technique," Volume 13 Number 10, *Journal of Optics*. Impact factor: 1.99, 2011.
21. Hamid Ali Abed Al-Asadi, "Architectural Analysis of Multi-Agents Educational Model in Web-Learning Environments," *Journal of Emerging Trends in Computing and Information Sciences*, Vol. 3, No. 6, June 2012.
22. Boselin Prabhu S.R. and Sophia S., 'Hierarchical distributed clustering algorithm for energy efficient wireless sensor networks', *International Journal of Research in Information Technology*, 1(12), 2013.
23. Boselin Prabhu S.R. and Sophia S., 'Real-world applications of distributed clustering mechanism in dense wireless sensor networks', *International Journal of Computing Communications and Networking*, 2(4), 2013.